



BILGE PUMP

Features

- Patented X-Air™ anti-airlock impeller
- Non Return Valve recommended for any installation

Certifications, Standards and Listings:

The Tsunami Mk2 pumps meet or exceed the following U.S. and international standards

- Bilge pumps standards
 - ABYC H-22
 - ISO 8849
 - ISO 15083
- Ignition Protection Standards
 - ISO 8846 Marine
- Marine Electrical Wiring Standards
 - ABYC E-11
 - ISO 10133
- Approvals: NMMA “As approved Listing”; CE; RCM; UKCA



Part No.	NMMA	CE	RCM	UKCA
5606 Series	✓	✓	✓	✓
5608 Series	✓	✓	✓	✓
5609 Series	✓	✓	✓	✓
5512 Series	✓	✓	✓	✓
5513 Series	✓	✓	✓	✓

Model	Rated Voltage (D.C)	Fuse Size*	Outlet Type	Check Valve	Wire Length	Bulk Packaging	Retail Packaging
T500	12-Volt	3 Amp	3/4" (19mm) & 1" (25mm) Barbs	Y	29" (735mm)	-	5606-7
			3/4" (19mm) Barb	N		5606B-1	-
			1-3/8" Threaded*	Optional		5606-1	-
T800	12-Volt	4 Amp	3/4" (19mm) & 1" (25mm) Barbs	Y		-	5608-7
			3/4" (19mm) Barb	N		5608B-1	-
			1-3/8" Threaded*	Optional		5608-1	-
T800	24-Volt	2 Amp	3/4" (19mm) & 1" (25mm) Barbs	Y		-	5609-7
			3/4" (19mm) Barb	N		5609B-1	-
			1-3/8" Threaded*	Optional		5609-1	-
T1200	12-Volt	5 Amp	3/4" (19mm) & 1" (25mm) Barbs	Y	-	5612-7	
			3/4" (19mm) Barb	N	5612B-1	-	
			1-3/8" Threaded*	Optional	5612-1	-	
T1200	24-Volt	2 Amp	3/4" (19mm) & 1" (25mm) Barbs	Y	-	5613-7	
			3/4" (19mm) Barb	N	5613B-1	-	
			1-3/8" Threaded*	Optional	5613-1	-	
Materials			PC/BT Lid & Cartridge Body, ABS Basket, PP (GF) Pump Body & Fittings, POM Fittings, PBT (GF) Impeller, SS316 Motor Shaft, Nitrile Seals				
Minimum Water Level			2/5" (10mm)				
IP Rating			IP68				

Automotive Blade Type Fuses Recommended

*Please order the correct outlet type to suit your needs (NRVs come as standard)

Tsunami Mk2 Mounting Holes

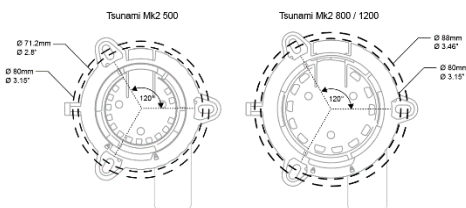

Tsunami Mk2 Retrofit Options

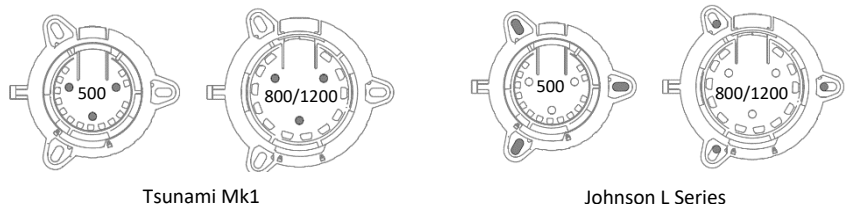



BILGE PUMP

500 Dimensions

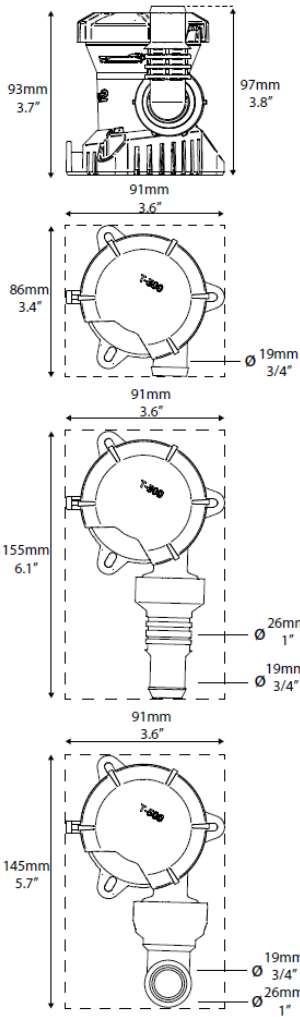

800 Dimensions

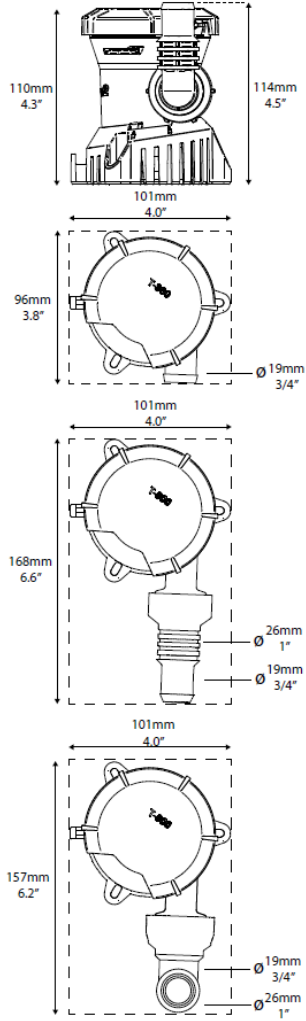

1200 Dimensions

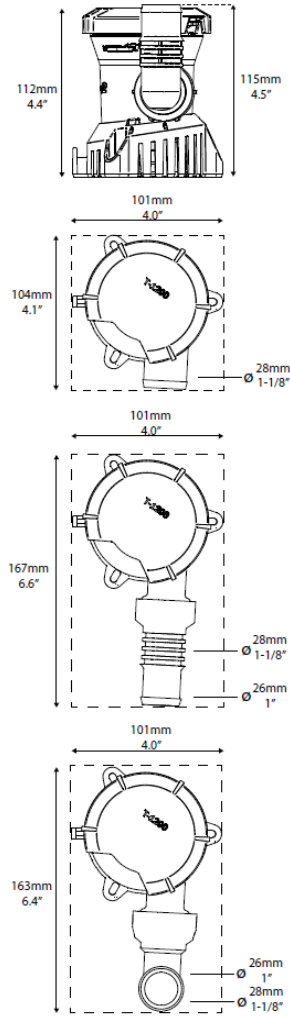

Current Draw

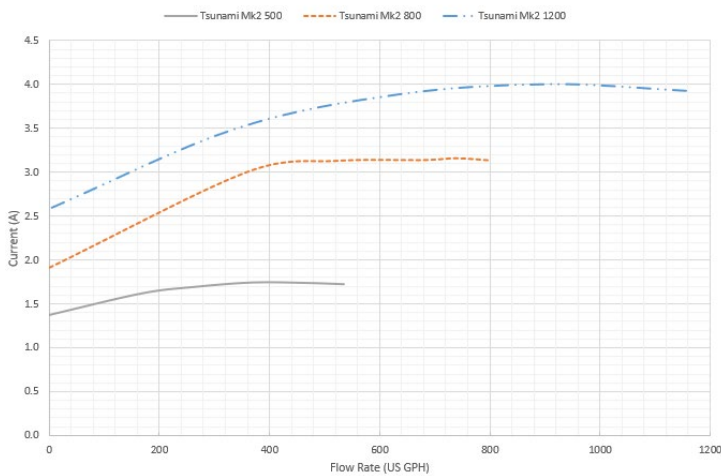

Flow Rate

