

THIS DRAWING AND THE INFORMATION CONTAINED WITHIN IT ARE CONFIDENTIAL AND MAY NOT BE COPIED OR DISCLOSED WITHOUT THE WRITTEN PERMISSION OF BLUE SEA SYSTEMS.

REVISIONS

| ZONE | REV. | DESCRIPTION | DATE | APPROVED |
|------|------|-------------|------|----------|
| - | - | - | - | - |

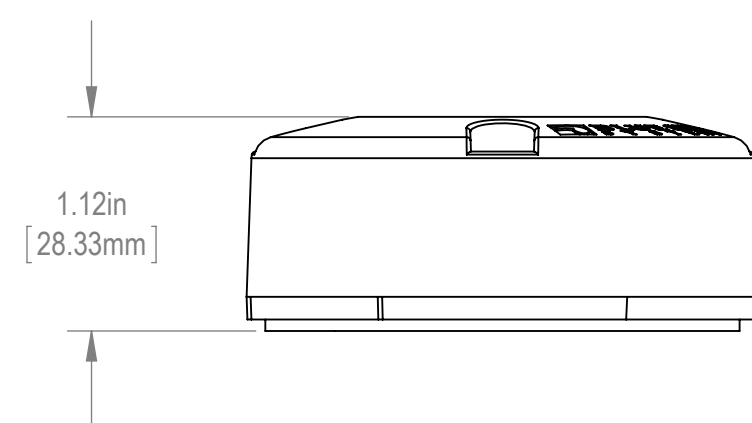
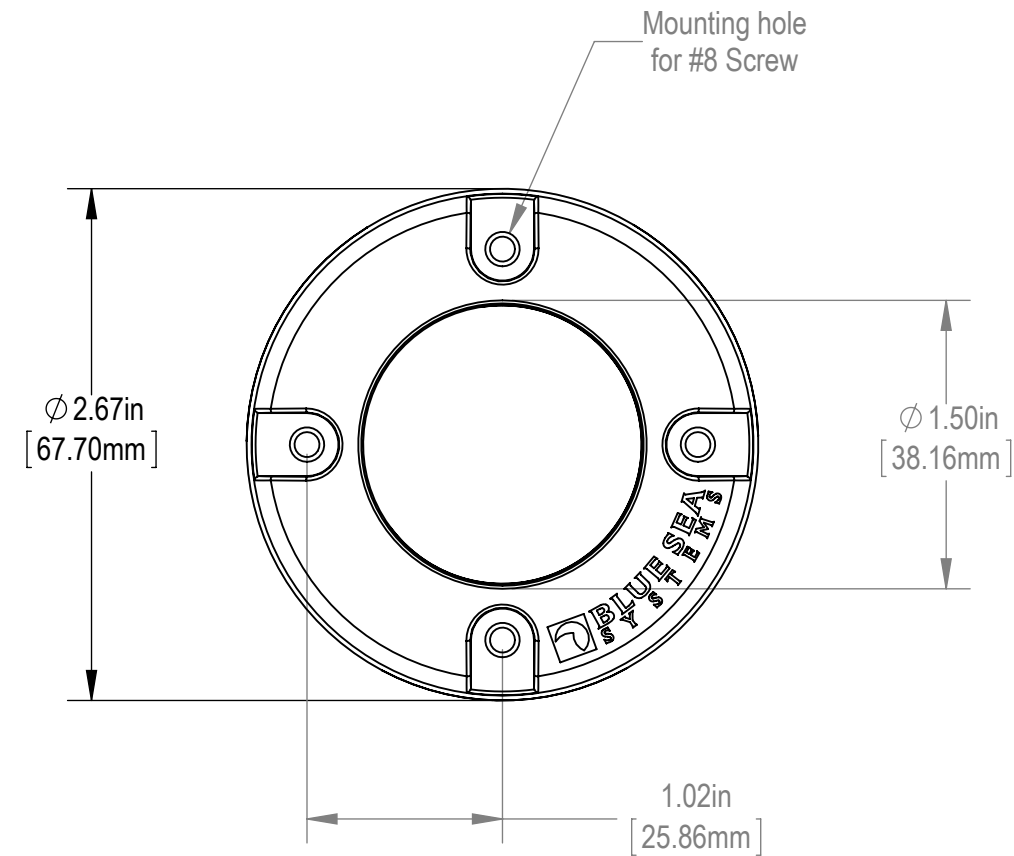

THIRD ANGLE PROJECTION



DIMENSIONS ARE SHOWN IN INCHES AND [MILLIMETERS]. UNSPECIFIED TOLERANCES ARE:

| ANGLES | INCH | MM |
|--------------------|------------------|-----------------|
| $\pm 0^{\circ}30'$ | .0000 \pm .002 | .000 \pm .051 |
| | .000 \pm .005 | .00 \pm .127 |
| | .00 \pm .010 | .0 \pm .254 |

MATERIAL --

FINISH --

DO NOT SCALE DRAWING

| | NAME | DATE |
|---------|------|------|
| DRAWN | - | - |
| CHECKED | - | - |
| - | - | - |
| - | - | - |
| - | - | - |
| - | - | - |

COMMENTS:



Part Number ----

| SIZE | DWG. NO. | REV. |
|-----------|-----------------------------|--------------|
| B | 1003-1 CableClam 1.385 Inch | A |
| SCALE 1:1 | WEIGHT: POUNDS | SHEET 3 OF 8 |